

LAMSON CENTRIFUGAL BLOWERS, 1 Lamson St., P.O. Box 4857 Syracuse, NY 13221, (315) 433-5500.
FAX (315) 433-5451, 1 (800) 543-7736

For Approval Certified For

Project _____

Your Order # _____

Our Order # _____ By _____

**"860" Series
Air & Gas, Inlet Driven
Direct Drive - Dimensions**

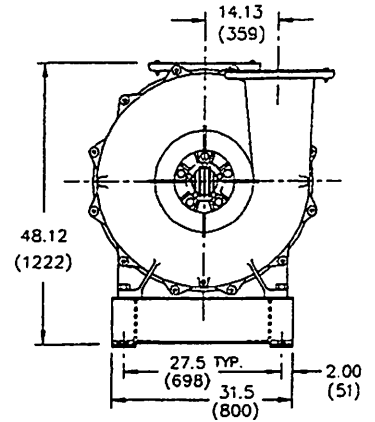
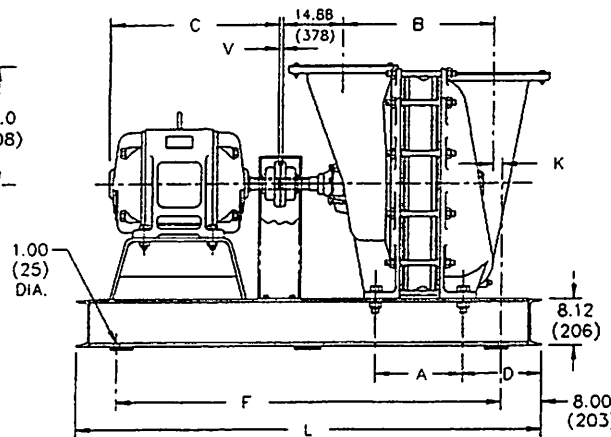
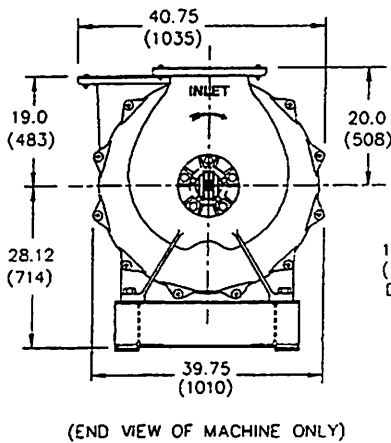
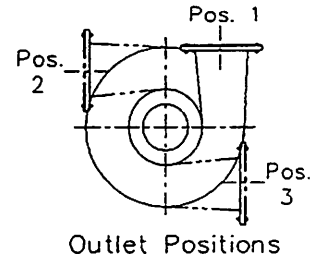
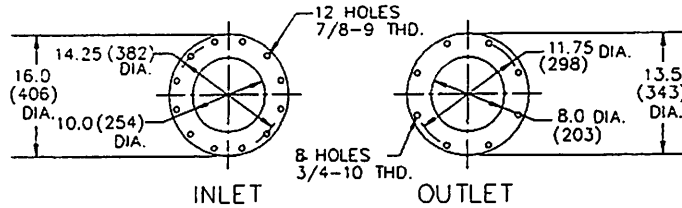
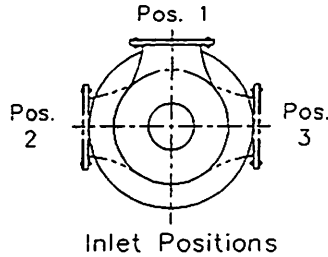

Frame No.	Dimensions						
	A	B	C	D	F	L	K
861	8.50 (216)	13.50 (343)	284TS	12.50 (317)	54 (1372)	70 (1778)	3.50 (89)
862	13.38 (340)	18.38 (467)	326TS	17.38 (441)	67 (1702)	83 (2018)	8.38 (213)
863	18.25 (464)	23.25 (591)	365TS	12.50 (317)	67 (1702)	83 (2018)	3.50 (89)
864	23.13 (588)	28.13 (714)	405TS	12.50 (317)	74 (1880)	90 (2286)	3.50 (89)
865	28.00 (711)	33.00 (838)	444TS	17.38 (441)	88 (2235)	104 (2642)	8.38 (213)
866	32.88 (835)	37.88 (962)	445TS	12.50 (317)	88 (2235)	104 (2642)	3.50 (89)
867	37.75 (959)	42.75 (1086)	445TS	12.50 (317)	93 (2362)	109 (2769)	3.50 (89)
868	42.62 (1083)	47.63 (1210)	447TS	17.38 (441)	111 (2819)	127 (3226)	8.38 (213)
869	47.50 (1207)	52.50 (1334)	447TS	12.50 (317)	111 (2819)	127 (3226)	3.50 (89)
8610	52.38 (1330)	57.38 (1457)	449TS	12.50 (317)	116 (2946)	132 (3353)	3.50 (89)

NOTES:

- Column "C" lists maximum NEMA motor frame typically required for the machine indicated.
- Dimensions in inches and (mm).
- Flange dimensions conform to 125 pound ANSI cast iron flanged fittings.

- Dimension "V" is distance between shaft ends which varies depending on the coupling used. Refer to coupling data sheet for more information.
- Specifications subject to change without notice.

LAMSON CENTRIFUGAL BLOWERS, 1 Lamson St., P.O. Box 4857 Syracuse, NY 13221.(315) 433-5500.
FAX (315) 433-5451, 1 (800) 543-7736

**"860" Series
Air Outlet Driven
Direct Drive - Dimensions**

For Approval Certified For

Project _____
Your Order # _____
Our Order # _____ By _____

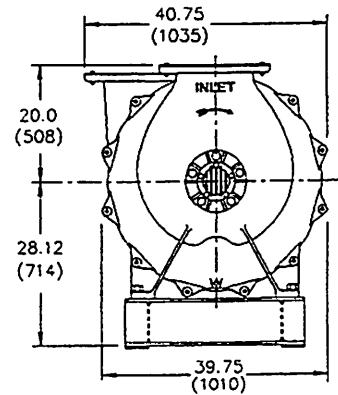
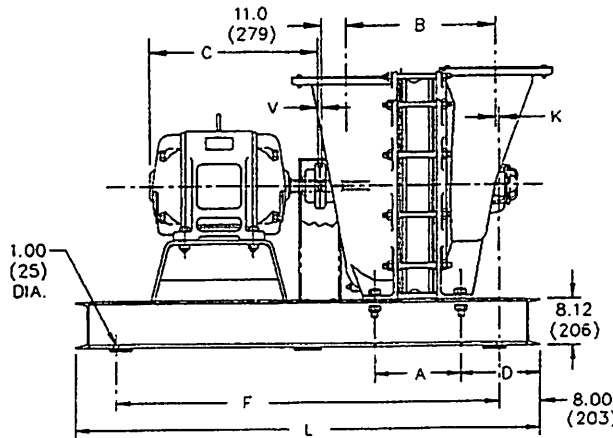
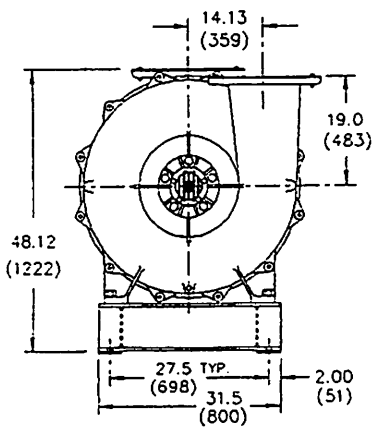
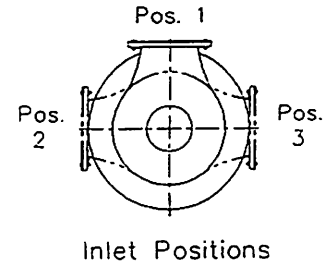
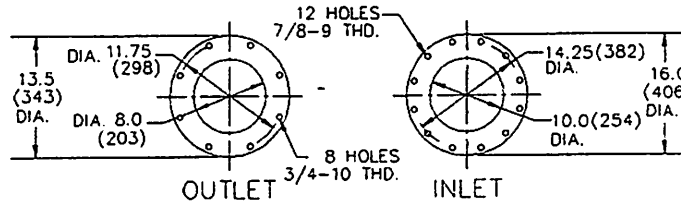
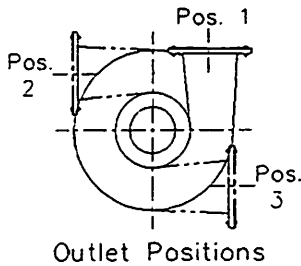

Frame No.	Dimensions						
	A	B	C	D	F	L	K
861	8.50 (216)	13.50 (343)	284TS	12.50 (317)	54 (1372)	70 (1778)	.50 (13)
862	13.38 (340)	18.38 (467)	326TS	17.38 (441)	67 (1702)	83 (2018)	5.38 (137)
863	18.25 (464)	23.25 (591)	365TS	12.50 (317)	67 (1702)	83 (2018)	.50 (13)
864	23.13 (588)	28.13 (714)	405TS	12.50 (317)	74 (1880)	90 (2286)	.50 (13)
865	28.00 (711)	33.00 (838)	444TS	17.38 (441)	88 (2235)	104 (2642)	5.38 (137)
866	32.88 (835)	37.88 (962)	445TS	12.50 (317)	88 (2235)	104 (2642)	.50 (13)
867	37.75 (959)	42.75 (1086)	445TS	12.50 (317)	93 (2362)	109 (2769)	.50 (13)
868	42.62 (1083)	47.63 (1210)	447TS	17.38 (441)	111 (2819)	127 (3226)	5.38 (137)
869	47.50 (1207)	52.50 (1334)	447TS	12.50 (317)	111 (2819)	127 (3226)	.50 (13)
8610	52.38 (1330)	57.38 (1457)	449TS	12.50 (317)	116 (2946)	132 (3353)	.50 (13)

NOTES:

- Column "C" lists maximum NEMA motor frame typically required for the machine indicated.
- Dimensions in inches and (mm)
- Flange dimensions conform to 125 pound ANSI cast iron flanged fittings.
- Dimension "V" is distance between shaft ends which varies depending on the coupling used. Refer to coupling data sheet for more information.
- Specifications subject to change without notice.